

## USE AND MAINTENANCE MANUAL

# ROTARY TILLER TYPE THUNDER



## PREFACE

### **This manual is an integral part of the machine.**

It must always accompany the machine and be kept within reach of the operator.  
The enclosures mentioned are an integral part of this manual.

### **The purpose of this manual.**

This manual gives information for the correct and safe use of the machine.  
The owner must read this manual carefully before work with the machine.

### **Responsibility of the owner**

The owner is responsible for accidents or damages caused to people or things due to negligence in following the instructions in this manual.

### **Assistance in using this manual**

Explanations: contact the dealer.

Request for additional copies of the manual: in case of loss or wear and tear, or in case one wants the manual in a different language, the customer should ask the dealer or manufacturer.

### **Pay attention to the warning signals**



**<Danger>**: indicates a situation that is potentially dangerous which, if not avoided, will cause death or serious damage.



**<Warning>**: indicates a situation that is potentially dangerous which, if not avoided, will cause death or serious damage.



**<Caution>**: indicates a situation that is potentially dangerous which, if not avoided, can cause minor to moderate damage or it indicates to be careful about an unsafe procedure.

**<Important>**: indicates instructions that must be followed precisely in order to avoid damage to the product, process or environment.

**<Note>**: indicates supplementary information.

<b>DESCRIPTION</b>
--------------------

### **FUNCTION OF USE**

The machine, thanks to the large range of types, carries out all the function related with tools rotation in various work environment (open field, vineyards, orchards, flower gardens, parks, vegetable gardens), in all type of ground whatever its composition (sandy soil, medium mixture, clay) and consistency (crumbly, hard, semi-plastic) may be.

The use of a technical constructive concept trended to the search of high performances, reduction of troubles and durability, improves the power/consumption ratio of the tractor thanks to the elasticity of the machine frame, to the tools shape and to many original technical solutions.

### **PERFORMANCES**

The machine is connected to the tractor with a three points hitch that gives the motion of translation and with a PTO shaft connected with the tractor PTO that gives the motion of rotation to the hoes shaft.

The working width is fix and it's determined from the choice of the machine type.

The working depth is adjustable.

The rear baffle besides prevents a dangerous hurling of stones and other foreign bodies, makes a clod mincing function the more emphasized the more the baffle is closed.

### **PERFORMANCES LIMITS**

- Maximum forwarding speed: 3 m.p.h.
- Speeds greater than the maximum can compromise the condition of the machine, the quality of the work and the safety of the operator.
- Maximum power applicable to the gear box: from 11 to 26 Kw  $\pm$  5% with 540 r.p.m.
- Superior power to which is indicated can damage irreparably the transmission gear box; especially during heavy works.
- Max working depth: from 6 to 7 inches.

---

### **STANDARD EQUIPMENT**

- **Standard PTO shaft.**

### **VARIANTS & OPTIONS**

- **Bolt PTO shaft.**
- **Clutch PTO shaft.**
- **Front safety protection.**

<b>TECHNICAL SPECIFICATION</b>
--------------------------------

**CHARACTERISTICS PER MODEL**

Model	Type	Power		Working width		Weight		Working depth		Total width		N° of hoes	
		HP	KW	cm.	inch	Kg.	lbs.	cm.	inch	cm.	inch	n° flange	n° hoes
<b>THUNDER</b>	85	15-35	11-26	85	34	133	293	15÷17	6	97	38	4	16
	105	15-35	11-26	105	42	146	322	15÷17	6	117	47	5	20
	125	15-35	11-26	125	50	159	351	15÷17	6	137	55	6	24
	145	15-35	11-26	145	58	171	377	15÷17	6	157	62	7	28

## SAFETY INFORMATION

### GENERAL REGULATIONS

- ❑ Only work in daylight.
- ❑ The machine must not be used near people, especially children or animals.
- ❑ Wear long pants and heavy shoes.
- ❑ The protections are integral part of the machine: always work with the protections.
- ❑ Pay attention to the soil: make sure that are not stones, sticks, iron wires, etc...
- ❑ Pay attention using the machine on slopes: proceed to the maximum slope and never work in slanting direction.
- ❑ Before leaving the driver's seat, turn off the engine and disengage the transmission engine-shaft.
- ❑ Check immediately the machine if it touches foreign objects.
- ❑ Check immediately the machine if there are unusual strong vibrations.
- ❑ Change quickly defective parts.

### SAFETY RESTRICTIONS

Children and people who are not familiar with these instructions must not be permitted to use the machine. Local regulations can restrict the use of the machine in accordance to the age.

## SAFETY SIGNS ON THE MACHINES

In this section the safety signs on the machine are reproduced and explained.



1

2

3

4

5

6

1. Read the operator manual.
2. Disconnect the tractor key before maintenance and repair operations.
3. Don't remove safety protection.
4. Stay at safety distance from PTO shaft.
5. Danger of flying objects. Stay at safety distance.
6. Stay at safety distance from the blades.

### **The safety signs on the machine must always be legible.**

In case of damage, the labels of the signs must be substituted.

In the case of the substitution of machine parts that have safety signs, the signs must be replaced.

### **Supplying of new safety labels and the application procedure**

Contact your dealer to receive new safety labels with instructions for application.

## INSTRUCTION FOR USE

### BEFORE BEGINNING WORK

a) Adjust working depth as follows :

1. Unscrew nuts "B" and take out the screws.
2. Adjust working depth moving slide "A" towards up to increase and towards down to decrease.
3. Plug in the screws and lock nuts "B".
4. Repeat the same operations on the other machine side make sure to set up the same working depth on the two slides.

b) Adjust the baffle position operating as follows :

1. Take out the free side of the chain "D" from the housing slot.
2. Adjust the position of baffle "C" then put again the said of the chain in its housing slot.

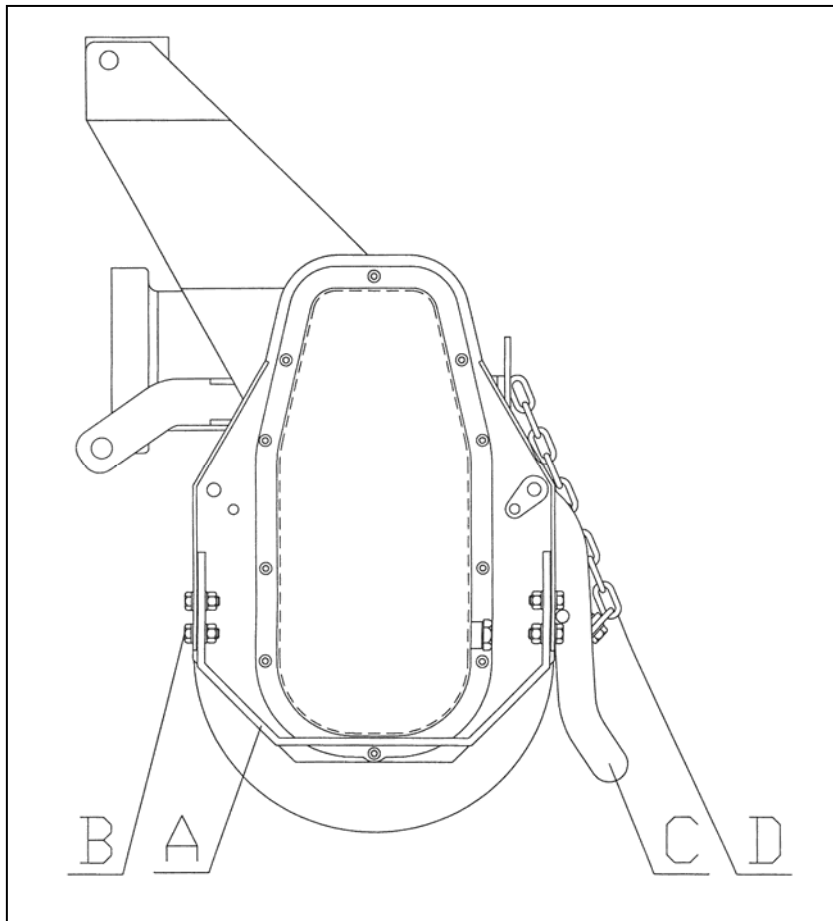

- c) Hook the machine to the tractor, operate as follows :
  1. Remove the safety pins then take out the pins from the two lower connection points of the machine.
  2. Plug in the raising tractor beams into the lower hitch points of the machine, plug in the pins, and lock with the safety pins.
  3. Connect through tie-rod the third hitch point of the tractor with the third point of the machine (the connection triangle vertex), insert the pin and lock with safety pin.
- d) With the machine raised, go to work area.
- e) Connect the tractor PTO with machine PTO.
- f) Check that PTO chain is locked to prevent the protection sheet of PTO rotating.

### **TO BEGINNING WORK**

- a) Keep people and animals at least 65 feet radius all around the machine.
- b) Pull down the machine until the hoes touch the ground.
- c) Connect PTO power and gradually bring it to 540 r.p.m..
- d) Pull down completely the machine and start to work.

### **AT THE END OF WORK**

- a) Stop the tractor.
- b) Raise the machine until the hoes goes out from ground.
- c) Disconnect PTO power.
- d) Disconnect tractor PTO from machine PTO.
- e) Raise completely the machine.



## REVERSE SET-UP

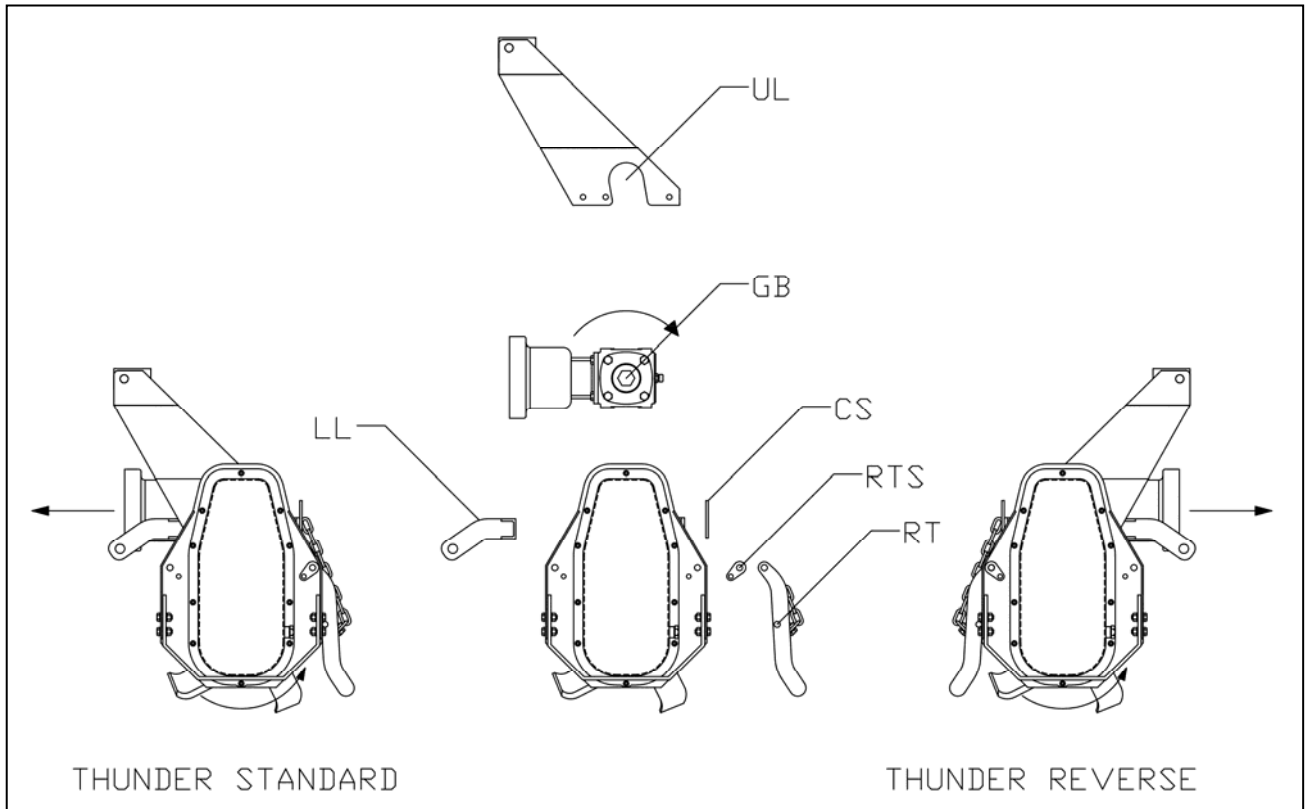

To set-up Thunder as Reverse rotary tiller operate as follow:

- Disassemble from the deck the upper linkage "UL", the right and left lower linkages "LL", the rear tail "RT" taking out the 2 stopper "RTS", the chain holder "CS" and the gear box "GB".
- Turn 180 degree the gear box "GB", to make this operation is enough to rise a little the gear box from the deck before turning, fix again the gear box on the deck.
- Assemble again the rear tail "RT" using the 2 stopper "RTS" and the chain holder "CS" on the opposite side of the deck.
- Assemble again the upper linkage "UL" and the right and left lower linkage "LL" on the opposite side of the deck

## MAINTENANCE INSTRUCTIONS

On diagram "A" the maintenances are indicated with their terms to effect on the machine.  
 Not follow the scheduled terms can compromise the functionality of the machine and in this case the warranty is not applicable.

### DIAGRAM "A" SCHEDULED MAINTENANCE

	<b>FIRST START</b>	<b>AFTER 10 HOURS</b>	<b>EACH 30 HOURS</b>	<b>EACH 500 HOURS</b>	<b>END SEASON</b>	<b>BEGIN. WORK</b>	<b>END WORK</b>
<b>MACHINE</b>	Greasing		Greasing		Cleaning Greasing		Cleaning
<b>ANGULAR GEAR BOX</b>	Oil level	Oil level	Oil level	Change oil			
<b>TRANSMISSION BOX</b>	Oil level	Change oil	Oil level	Change oil			
<b>SCREWS</b>		Locking	Locking				
<b>HOES</b>			Check		Check	Check	Check

## 1. GREASING

At the scheduled time on diagram "A", grease points "B-C-D".

Greasing points are equipped with greaser HYDRAULIC TYPE MODEL "A" UNI 7663.

To greasing use only MULTIFUNCTIONAL GREASE LITHIUM BASED Type NLGI 2.

## 2. OIL CHECK - OIL SUBSTITUTION IN GEAR BOX

At the scheduled time on diagram "A", check or substitute oil into gear box.

To fill oil use only OIL SAE 140 EP.

Gear box capacity: 1 L

a) To check the oil level in gear box, operate as follows :

1. With the machine on level unscrew the level plug "A" and check that oil touches lower hole rim.
2. If the level it's ok screw and lock plug "A".
3. If the level it's low, unscrew plug "A" and fill oil.
4. When the level it's ok screw and lock plug "A".

b) To replace oil in gear box, operate as follows :

1. Unscrew plugs "A"
2. Turn the machine of 90° in the direction of the arrow and drain the oil in a suitable tank.
3. Turn the machine on level.
4. Plug in the new oil from plug "A".
5. When level is ok screw and lock plug "A".

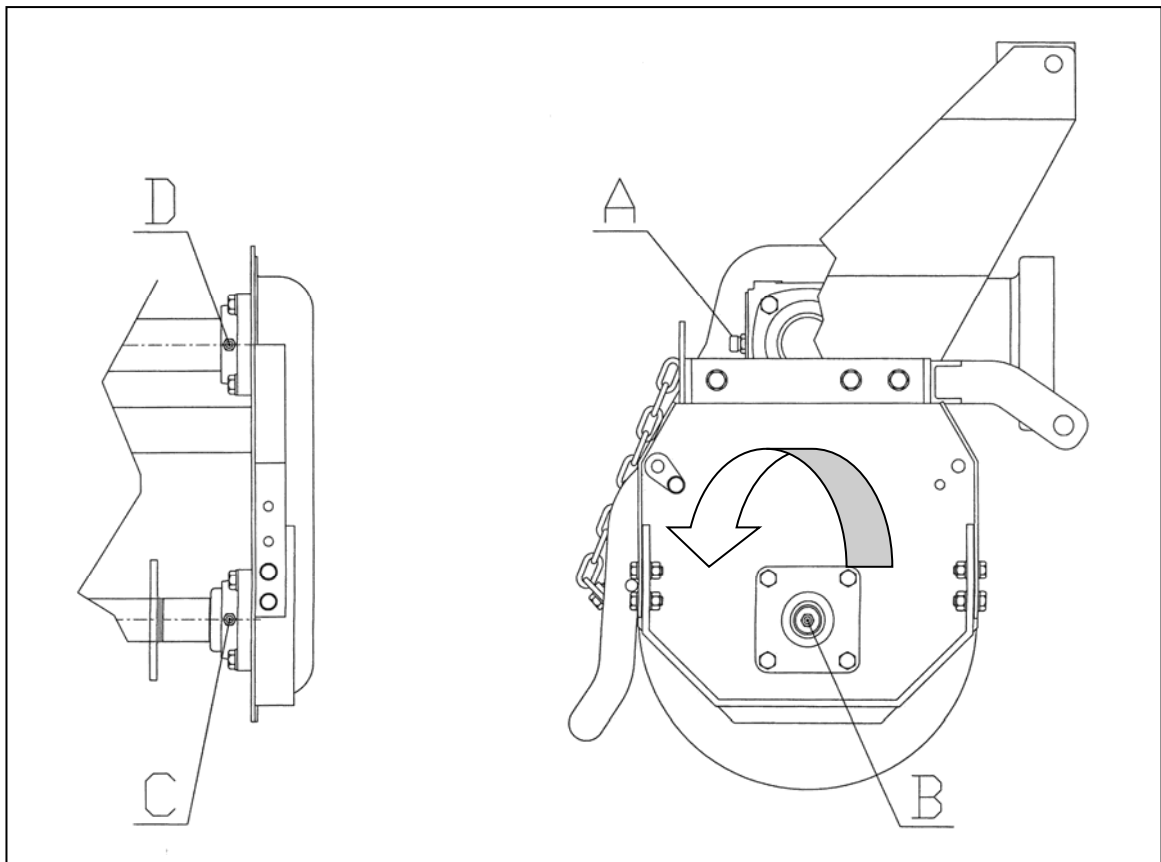

### 3. OIL CHECK - OIL SUBSTITUTION IN SIDE TRANSMISSION BOX

At the scheduled time on diagram "A", check or substitute oil into side transmission box.  
To fill oil use only OIL SAE 140 EP.  
Transmission gear box capacity: 2 L

- a) To check oil level in side transmission box, operate as follows :
1. With the machine on level unscrew the level plug "A" and check that oil touches lower hole rim.
  2. If the level it's ok screw and lock plug "A".
  3. If the level it's low unscrew plug "A" and fill oil.
  4. When the level it's ok screw and lock plug "A".
- c) To change oil in side transmission box, operate as follows :
1. Unscrew plug "A".
  2. Turn the machine of 90° in the direction of the arrow and drain the oil in a suitable tank.
  3. Turn the machine on level.
  4. Plug in the new oil from plug "A".
  5. When level it's ok screw and lock plug "A".

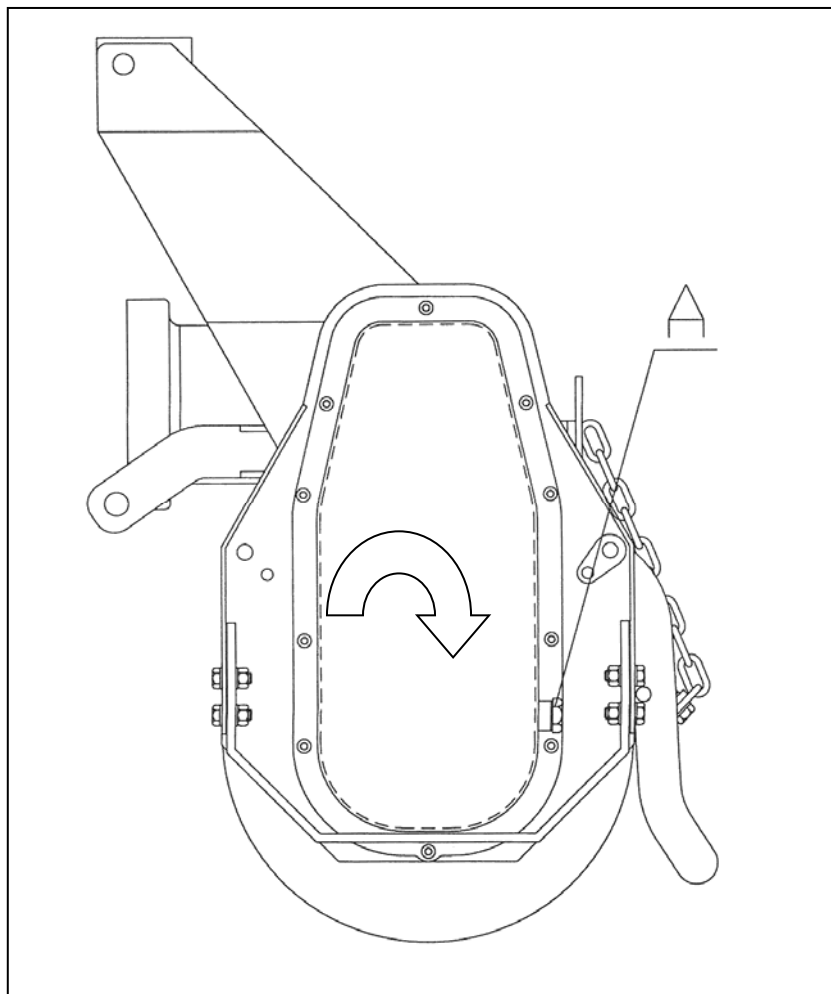

#### 4. HOES SUBSTITUTION

a) To change the hoes, operate as follows :

1. Unscrew the two nuts "A" that lock the screw of the hoes to change.
2. Take out the two screws from the holes and take out the hoe "B".
3. Put the new hoe using the new screws enclosed.
4. Lock with the nuts "A".
5. Repeat these operations for all the hoes to change.

**ATTENTION: on each flange are assembled 2 or 3 right hoes and 2 or 3 left hoes.**

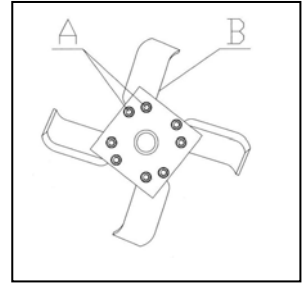

#### 5. CHAIN SUBSTITUTION

a) To change the chain, operate as follows :

1. Drain the oil from the carter making the first three phases showed at point "b)" chapter "3".
2. Remove the carter unscrewing the 10 screw.
3. Keeping out of its place the chain adjuster "C" remove the connection mesh "A" and take out chain "B".
4. Assemble the new chain, make sure to put well the safety spring of the connection mesh.
5. Assemble the carter using the new seal supplied with the new chain.
6. Put new oil in the carter making the last two phases showed at point " b)" chapter "3".

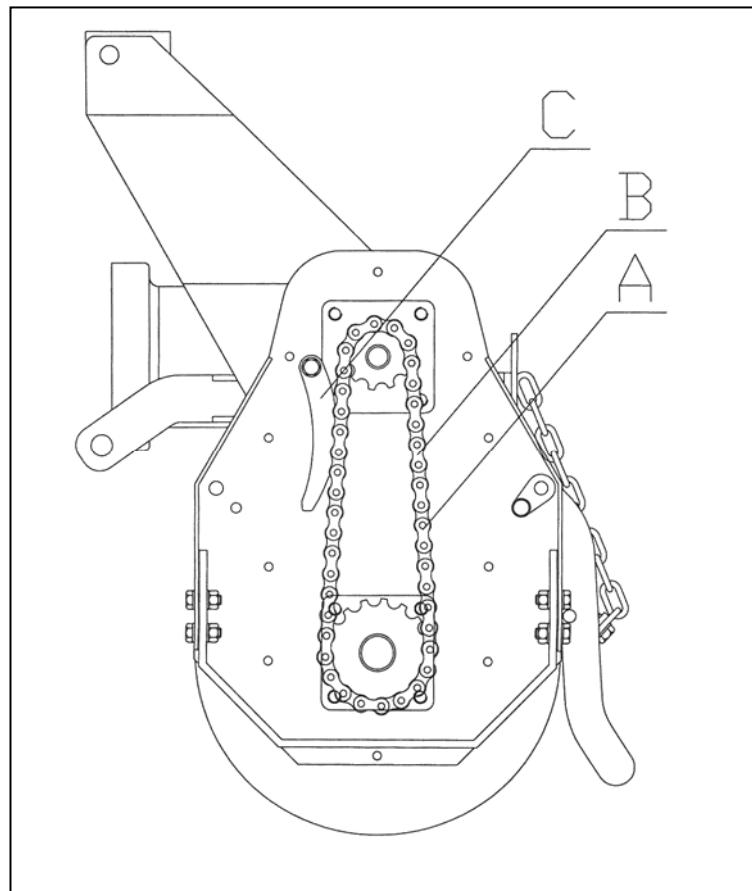

**PROBLEMS SOLVING**

<b>TROUBLES</b>	<b>CAUSES AND SOLUTIONS</b>
<b>Insufficient depth of work</b>	<ul style="list-style-type: none"> <li>-Decrease the forward speed</li> <li>-Increase the working depth (slides)</li> <li>-Broken hoes - Replace</li> <li>-Not balanced hoes - Balance</li> </ul>
<b>Hoes don't penetrate</b> <b>Tiller bounces on the ground and vibrates</b>	<ul style="list-style-type: none"> <li>-Broken or damaged hoes - Replace</li> <li>-Check the hoes assembling</li> <li>-Foreign objects between hoes - Clean</li> <li>-Soil too dry and hard - Decrease the forward speed</li> </ul>
<b>Rotor compactness, obstruction</b>	<ul style="list-style-type: none"> <li>-Soil too wet - Reduce depth of work</li> <li>-Increase number of revolutions of rotor</li> </ul>
<b>Excessive tilling of the soil</b>	<ul style="list-style-type: none"> <li>-Increase forward speed</li> <li>-Raise the rear baffle</li> <li>-Reduce number of revolutions of rotor</li> </ul>
<b>Poor tilling of the soil</b>	<ul style="list-style-type: none"> <li>-Decrease forward speed</li> <li>-Lower the rear baffle</li> <li>-Increase number of revolution of rotor</li> </ul>

## TRANSPORT

Except when working, moving the machine takes place when the machine is standing still and the transmission is disconnected.

<Important>: keep speed low avoiding holes and ground roughness.

<Important>: Before begin the movements always make sure that the safety hooks be in position.

<Note when on the road, obey existing traffic laws. Exhibit the signal signs on the rear ends. Respect any local laws there may be.

## STORAGE

Store the machine in a dry place that isn't dusty.

## INFORMATION ON DEMOLITION



At the end of its working life, the machine must be sent to be demolished and that can only be done by an authorized authority, in accordance with the national laws in force for the environment. Therefore it is necessary to get information from the qualified local authorities on the procedure to follow. The machine is mainly composed of: iron materials and paints.

## WARRANTY

The machine is covered by the manufacturer warranty for a period of 24 months.

The warranty is not applicable when:

- a) The maintenance work has not been done correctly.
- b) The machine has been used out of its own service.
- c) The machine has been transformed or modified without the manufacturer's written authorization.





## **SPARE PARTS AND OPTIONS**

THUNDER MECHANISMS

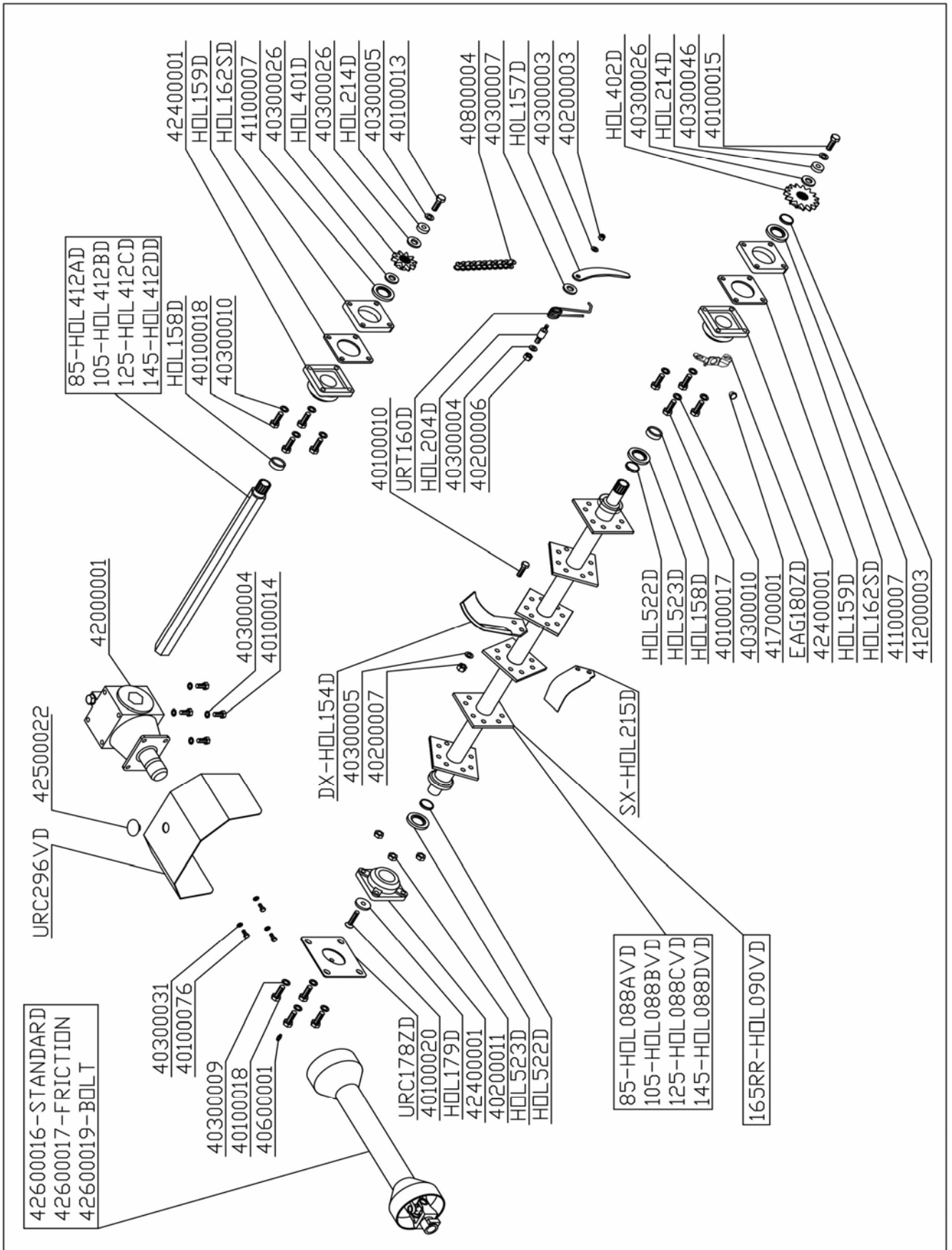

THUNDER FRAME COMPONENTS

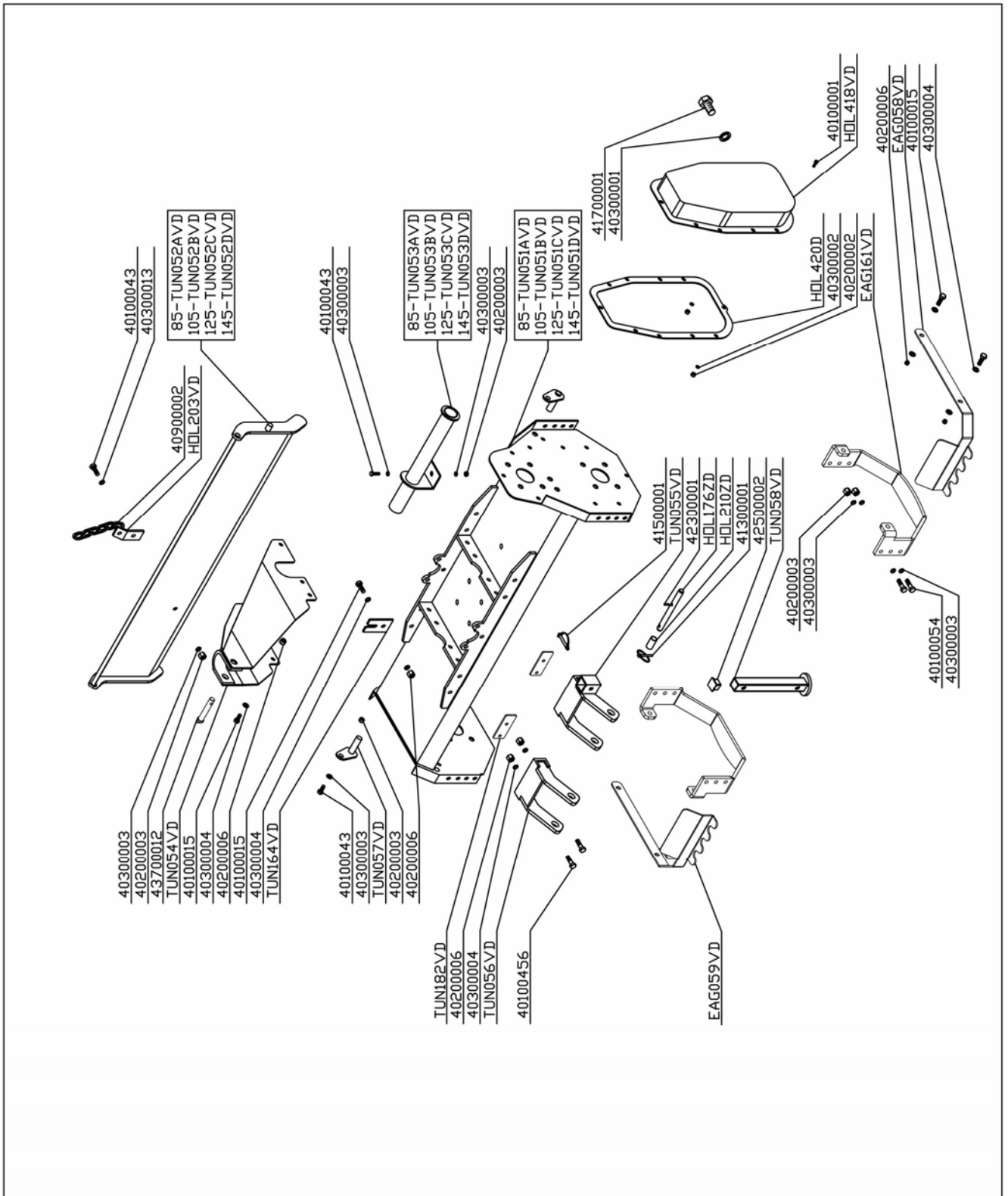

## GENERAL INDEX

<b>PREFACE</b> .....	<b>2</b>
<b>DESCRIPTION</b> .....	<b>3</b>
FUNCTION OF USE .....	3
PERFORMANCES.....	3
PERFORMANCES LIMITS .....	3
STANDARD EQUIPMENT .....	3
VARIANTS & OPTIONS.....	3
<b>TECHNICAL SPECIFICATION</b> .....	<b>4</b>
<b>SAFETY INFORMATION</b> .....	<b>5</b>
GENERAL REGULATIONS .....	5
SAFETY RESTRICTIONS .....	5
<b>SAFETY SIGNS ON THE MACHINES</b> .....	<b>6</b>
<b>INSTRUCTION FOR USE</b> .....	<b>7</b>
BEFORE BEGINNING WORK .....	7
TO BEGINNING WORK .....	8
AT THE END OF WORK .....	8
<b>REVERSE SET-UP</b> .....	<b>9</b>
<b>MAINTENANCE INSTRUCTIONS</b> .....	<b>10</b>
DIAGRAM "A" SCHEDULED MAINTENANCE .....	10
1. GREASING .....	11
2. OIL CHECK - OIL SUBSTITUTION IN GEAR BOX.....	11
3. OIL CHECK - OIL SUBSTITUTION IN SIDE TRANSMISSION BOX .....	12
4. HOES SUBSTITUTION .....	13
5. CHAIN SUSTITUTION.....	13
<b>PROBLEMS SOLVING</b> .....	<b>14</b>
<b>TRANSPORT</b> .....	<b>15</b>
<b>STORAGE</b> .....	<b>15</b>
<b>INFORMATION ON DEMOLITION</b> .....	<b>15</b>
<b>WARRANTY</b> .....	<b>15</b>
<b>WORK AND MAINTENANCE SHEET</b> .....	<b>16</b>
<b>THUNDER MECHANISMS</b> .....	<b>18</b>
<b>THUNDER FRAME COMPONENTS</b> .....	<b>19</b>

